

WD12 C8 - Teknik Özellikler

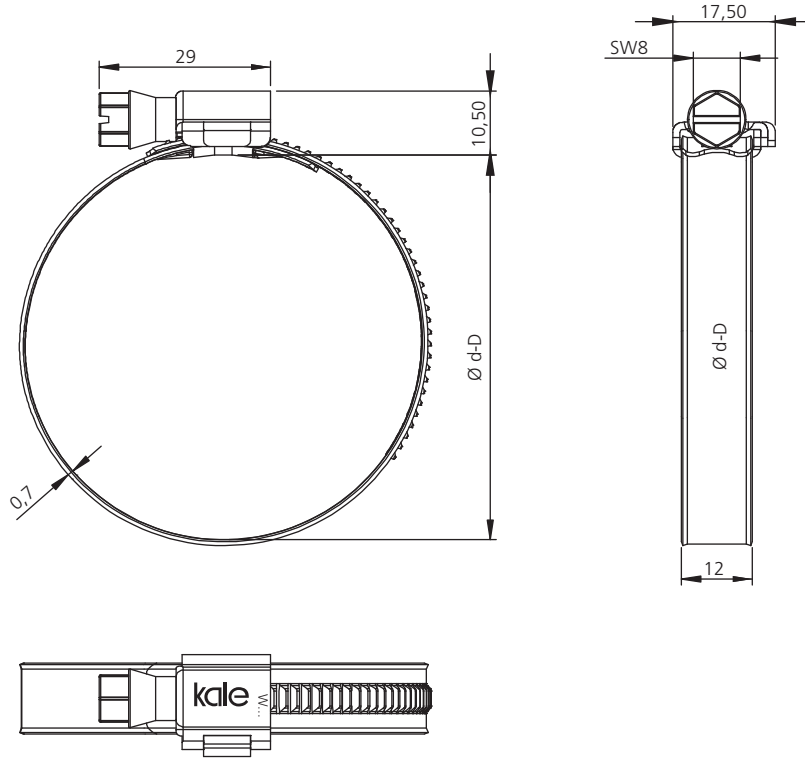

	W3	W4	W5
Vida	1.4016 DIN EN-10088-3 veya muadili	1.4567 DIN EN-10088-3 veya muadili	1.4578 DIN EN-10088-3 veya muadili
Yuva	1.4016 DIN EN-10088-2 veya muadili	1.4301 DIN EN-10088-2 veya muadili	1.4401 DIN EN-10088-2 veya muadili
Bant	1.4016 DIN EN-10088-2 veya muadili	1.4301 DIN EN-10088-2 veya muadili	1.4401 DIN EN-10088-2 veya muadili
Korozyon Direnci (min.saatt) ISO 9227	200*	240	400
Vida Başı			

* : Korozyon testi sonrası W3 ürünlerde toplam yüzeyin %10'unda kırmızı pas görülmesine müsaade edilir.

Ø d - D (mm) (min - max)	AD max. (Nm)
16-25	5,0
16-27	5,0
20-32	5,0
23-35	5,0
25-40	5,0
30-45	5,0
32-50	5,0
40-60	5,0
50-70	5,0
60-80	5,0
70-90	5,0
80-100	5,0
90-110	5,0
100-120	5,0
110-130	5,0
120-140	5,0
130-150	5,0
140-160	5,0
...
380-400	5,0

AD : Tavsiye edilen sıkma torku
Tavsiye edilen sıkma hızı 300 - 350d/dk