



Altı köşe vida başı ve ileri konum sayesinde montaj kolaylığı



Yaylı pullar sayesinde sabit sıkma kuvveti



%100 hortum emniyeti için iç yüzeyde ek bant



ST - Teknik Özellikler

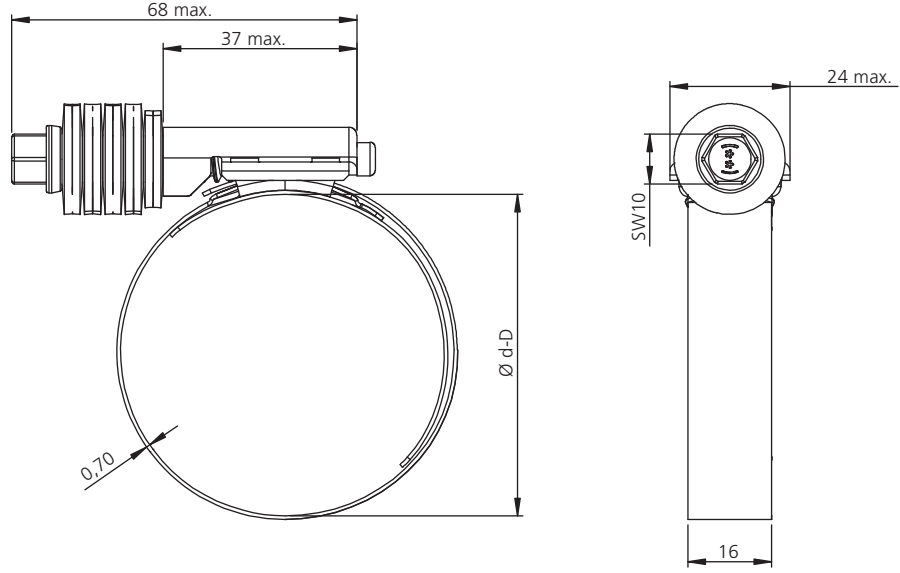

	W2
Vida	Karbon Çeliği *
Yuva	1.4301 DIN EN-10088-2 veya muadili
Bant	1.4301 DIN EN-10088-2 veya muadili
Çanak Yay	1.4310 DIN EN-10088-2 veya muadili
Köprü	1.4301 DIN EN-10088-2 veya muadili

* : Çinko kaplamalı

$\varnothing d - D$ (mm) (min - max)	AD max. (Nm)
25-45	8,5
32-54	8,5
45-67	8,5
57-79	8,5
70-92	8,5
83-105	8,5
95-117	8,5
108-130	8,5
121-143	8,5
133-155	8,5
146-168	8,5
159-181	8,5
172-193	8,5
184-206	8,5
197-219	8,5
210-232	8,5

AD : Tavsiye edilen sıkma torku